



## PRODUCT SPECIFICATION FOR LCD MODULE

MODULE NO. : ET-C1602A  
REVERSION : V5  
TYPE : COB

Customer Approval:

--	--	--	--

PREPARED BY		DATE	
CHECKED BY		DATE	
APPROVED BY		DATE	





## 1. General Specifications

Item	Standard Value	Unit
Number of dots	80 (W)X16(H)	dots
Display Pattern	<input type="checkbox"/> Dot-Graphic <input checked="" type="checkbox"/> Character <input type="checkbox"/> Digits <input type="checkbox"/> with ICON <input type="checkbox"/> _____	
Module Dimension	240(W) X30(H) X 30 (T)	mm
Viewing Area	64.5(W) X 13.8(H)	mm
Active Area	57.7(W) x 9.4(H)	mm
DOT Size	0.55(W) x 0.5(H)	mm
DOT Pitch	0.6(W) x 0.55(H)	mm
LCD Type	<input type="checkbox"/> TN, Positive <input type="checkbox"/> TN, Negative <input type="checkbox"/> HTN, Positive <input type="checkbox"/> HTN, Negative <input type="checkbox"/> STN, Yellow-Green <input type="checkbox"/> STN, Gray <input type="checkbox"/> STN, Blue <input type="checkbox"/> FSTN, Positive <input type="checkbox"/> FSTN, Negative <input type="checkbox"/> Color STN <input type="checkbox"/> FM LCD	
Polarizer Type	<input type="checkbox"/> Transmissive <input type="checkbox"/> Reflective <input type="checkbox"/> Transflective <input type="checkbox"/> Anti-Glare	
View Direction	<input type="checkbox"/> 6H <input type="checkbox"/> 12H <input type="checkbox"/> _____	
Operation Voltage	<input type="checkbox"/> 3.0(3.3) <input type="checkbox"/> 5.0 <input type="checkbox"/> _____	V
DC-DC Converter	<input checked="" type="checkbox"/> Build-in <input type="checkbox"/> External	
LCD Controller & Driver	SPLC780D &SPLC100A2	
LCD Driving Method	1/16duty, 1/5bias	
Interface Type	<input checked="" type="checkbox"/> 6800 <input type="checkbox"/> 8080 <input type="checkbox"/> I2C <input type="checkbox"/> Serial <input type="checkbox"/> SPI	
Backlight Type	<input checked="" type="checkbox"/> LED <input type="checkbox"/> CCFL <input type="checkbox"/> EL <input type="checkbox"/> no Backlight <input type="checkbox"/> _____	
Backlight Led Position	<input type="checkbox"/> Bottom <input type="checkbox"/> Side	
Backlight Color	<input type="checkbox"/> Yellow-Green <input type="checkbox"/> White <input type="checkbox"/> Amber <input type="checkbox"/> Blue <input type="checkbox"/> Red <input type="checkbox"/> _____	
EL/CCFL Driver type	<input type="checkbox"/> Build-in <input type="checkbox"/> External	
Woke Life(at ambient temperature and moisture)	<input type="checkbox"/> 30000(Side Led、CCFL) <input type="checkbox"/> 20000(Bottom Led) <input type="checkbox"/> 5000(EL)	
Supply current(type)	<input type="checkbox"/> _____	
Operation Temperature(oC)	-20-70 (TOPL – TOPH)	deg..
Storage Temperature (oC)	-30-80 (TSTL -- TSTH)	deg..

Note:

1. Label "■" means the option selected.
2. For detailed information please refer to IC SPLC780D data sheet (or full compatible IC KS0066, S6A0069).

## 2. External Dimensions

**SHEN ZHEN ET TECHNOLOGY CO., LTD.**

Tel: 86-755- 88834445  
E-mail: east@eastet .com

Fax: 86-755-88834446  
Http://www.eastet.com

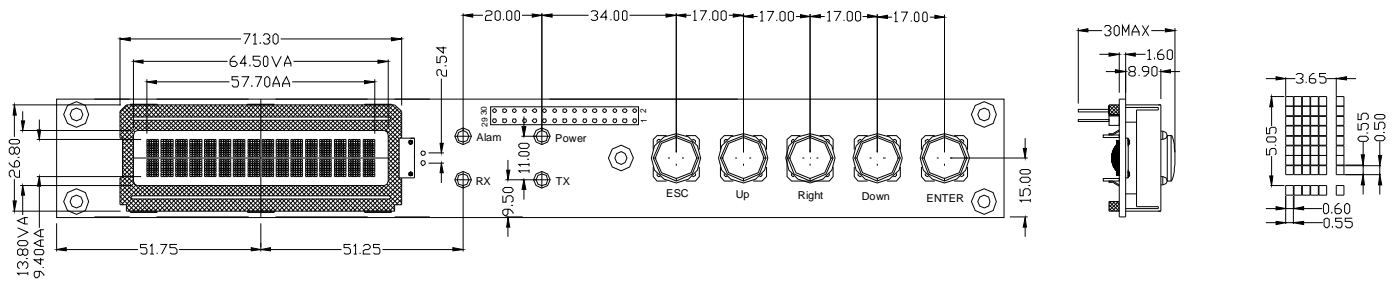

### 3. Block Diagram

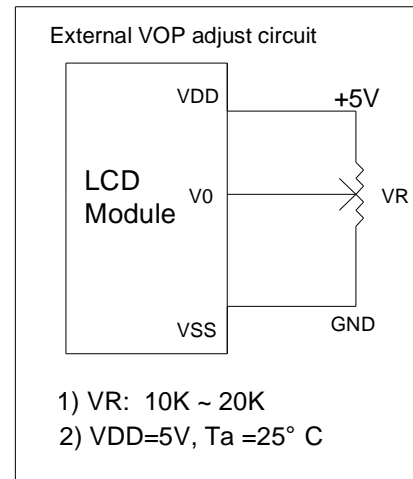
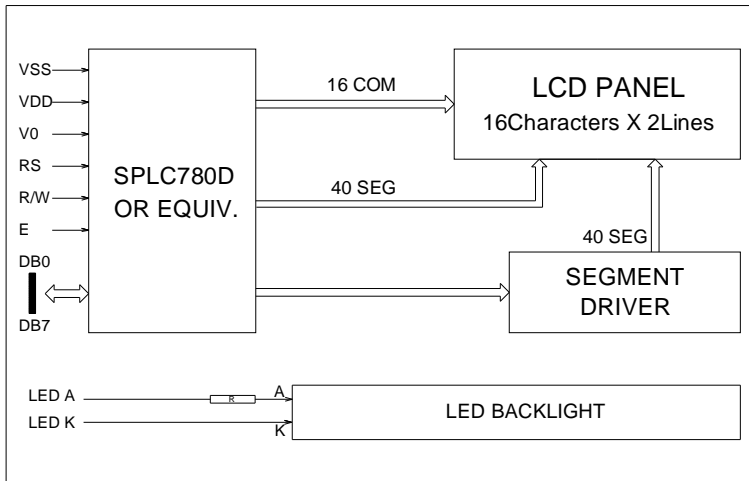

### 4. Pin Description

Pin	Name	Level	Function
1	VDD	0V	Ground
2	VSS	5.0V	Supply voltage for logic Ground
3	VO		Operating Voltage for LCD
4	RS	H/L	H: DB<0:7> Display RAM Data, L: DB<0:7> Instruction Data
5	R/W	H/L	H: Read mode, L: Write mode



6	E	H, H→L	Chip enable signal
7	DB0	H/L	Data bit 0
8	DB1	H/L	Data bit 1
9	DB2	H/L	Data bit 2
10	DB3	H/L	Data bit 3
11	DB4	H/L	Data bit 4
12	DB5	H/L	Data bit 5
13	DB6	H/L	Data bit 6
14	DB7	H/L	Data bit 7
15	BLA	5.0V	Power supply for LED backlight (+5V)
16	BLK	0V	Power supply for LED backlight ( 0V )
17	VCC	H/L	Indication Of Power LED
18	GND	H/L	Ground
19	LED1	H/L	Indication Of Alarm LED
20	LED4	H/L	---
21	LED2	H/L	Indication Of TX LED
22	LED5	5.0V	---
23	LED3	0V	Indication Of RX LED
24	ROW0	H/L	Button Of ROW0
25	COL0	H/L	Button Of COL0
26	ROW1	H/L	Button Of ROW1
27	COL1	H/L	Button Of COL1
28	ROW2	H/L	Button Of ROW2
29	GND	0V	Ground
30	GND	0V	Ground

## 5. Maximum Absolute Limit

### Maximum Absolute Power Ratings

Item	Symbol	Condition	Min	Max	Unit
Power Supply Voltage	Vdd	--	-0.3	7.0	V
LCD Drive Voltage	Vlcd	--	Vdd-15.0	Vdd+0.3	V
Input Voltage	Vin	--	-0.3	Vdd+0.3	V

## 6. Electrical Characteristics

### DC Characteristics (VDD = 4.5V to 5.5V, Ta = -30 to +85°C)

Characteristic	Symbol	Condition	Min	Typ	Max	Unit
----------------	--------	-----------	-----	-----	-----	------



Operating Voltage	VDD	-	4.5	-	5.5	V
Operating Current	IDD	Internal oscillation or external clock (VDD = 3.0V, fosc = 270kHz)	-	0.35	0.6	mA
Input Voltage (1) (except OSC1)	VIH1	-	2.2	-	VDD	V
	VIL1	-	-0.3	-	0.6	
Input Voltage (2) (OSC1)	VIH2	-	VDD-1.0	-	VDD	V
	VIL2	-	-0.2	-	1.0	
Output Voltage (1) (DB0 to DB7)	VOH1	IOH = -0.205mA	2.4	-	-	V
	VOL1	IOL = 1.2mA	-	-	0.4	
Output Voltage (2) (except DB0 to DB7) Voltage Drop	VOH2	IO = -40uA	0.9VDD	-	-	V
	VOL2	IO = 40uA	-	-	0.1VDD	
	VdCOM	IO = ± 0.1mA	-	-	1	V
	VdSEG		-	-	1	
Input Leakage Current	ILKG	VIN = 0V to VDD	-1	-	1	
Input Low Current	IIL	VIN = 0V, VDD = 5V (pull up)	-50	-125	-250	
Internal Clock (external Rf)	fOSC1	Rf = 91kΩ ±2% (VDD = 5V)	190	270	350	kHz
External Clock	fOSC2	-	125	270	350	kHz
	duty		45	50	55	%
	tR, tF		-	-	0.2	.
LCD Driving Voltage	VLCD	VDD-V5 (1/5, 1/4 bias)	3.0	-	13.0	V

**AC Characteristics (VDD = 4.5V ~ 5.5V, Ta = -30 ~ +85oC)**

Mode	Characteristics	Symbol	Min	Typ	Max	Unit
Write Mode	E Cycle Time	tc	500	-	-	ns
	E Rise / Fall Time	tR, tF	-	-	20	
	E Pulse Width (High, Low)	tw	230	-	-	
	R/W and RS Setup Time	tsu1	40	-	-	
	R/W and RS Hold Time	tH1	10	-	-	
	Data Setup Time	tsu2	80	-	-	
Read Mode	Data Hold Time	tH2	10	-	-	ns
	E Cycle Time	tc	500	-	-	
	E Rise / Fall Time	tR, tF	-	-	20	
	E Pulse Width (High, Low)	tw	230	-	-	
	R/W and RS Setup Time	tsu	40	-	-	



R/W and RS Hold Time	tH	10	-	-
Data Output Delay Time	tD	-	-	120
Data Hold Time	tDH	5	-	-

### 7. Read/Write Mode Timing

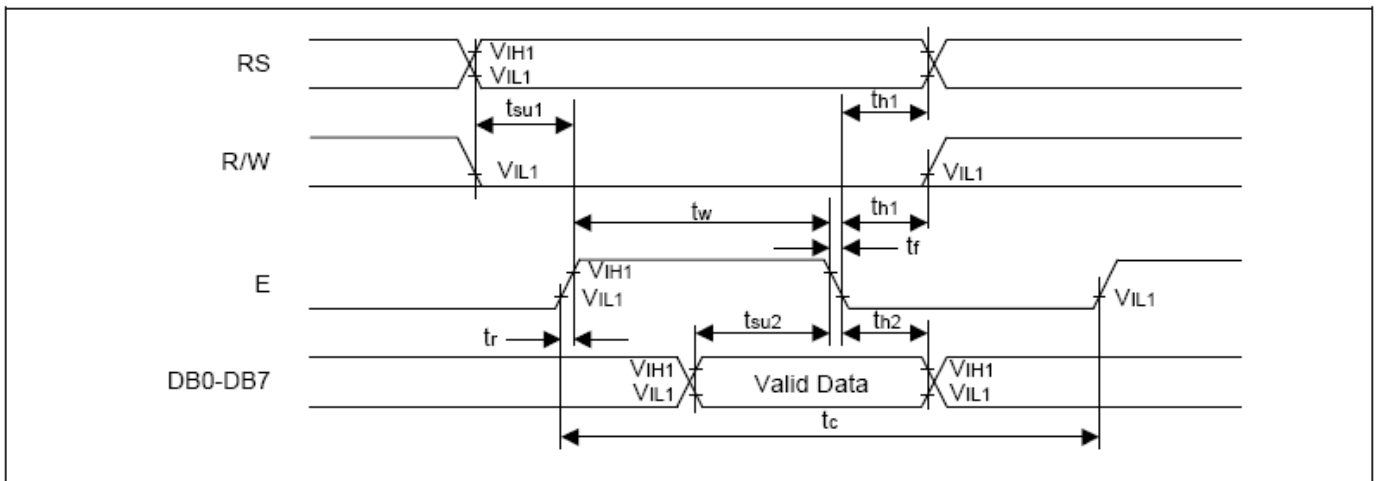

Figure 7.1 Write Mode Timing Diagram

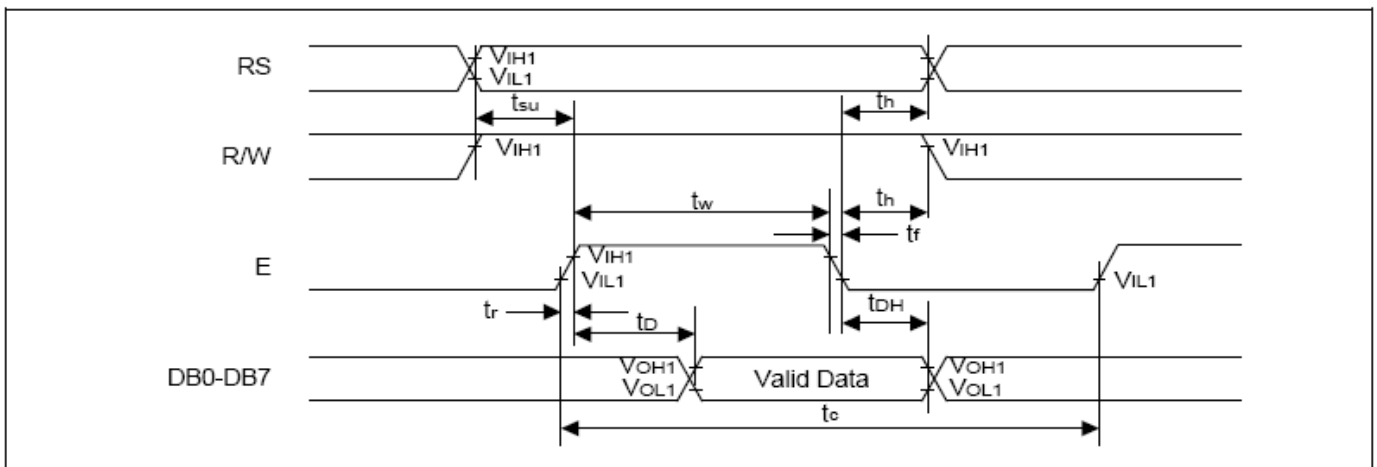

Figure 7.2 Read Mode Timing Diagram

## 8. Interface to MPU

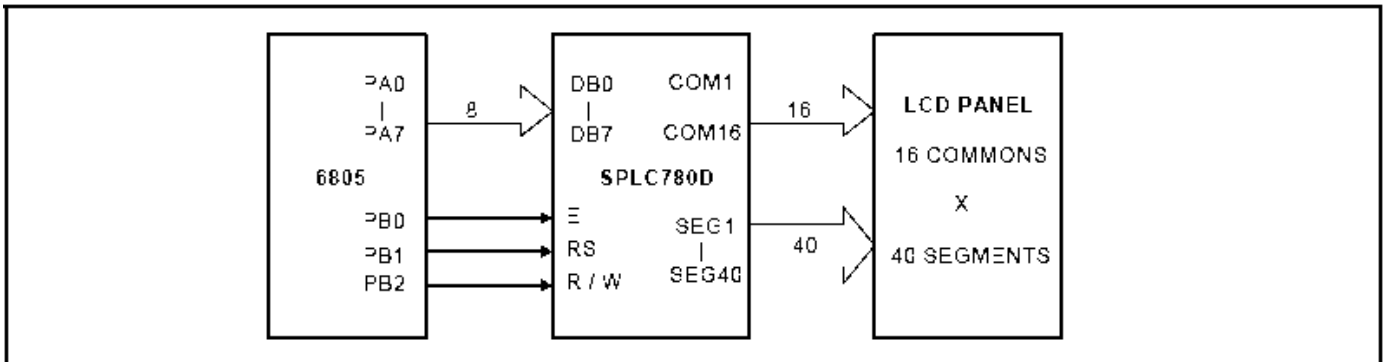

Figure 8.1 Interface to 8-bit MPU (6805)

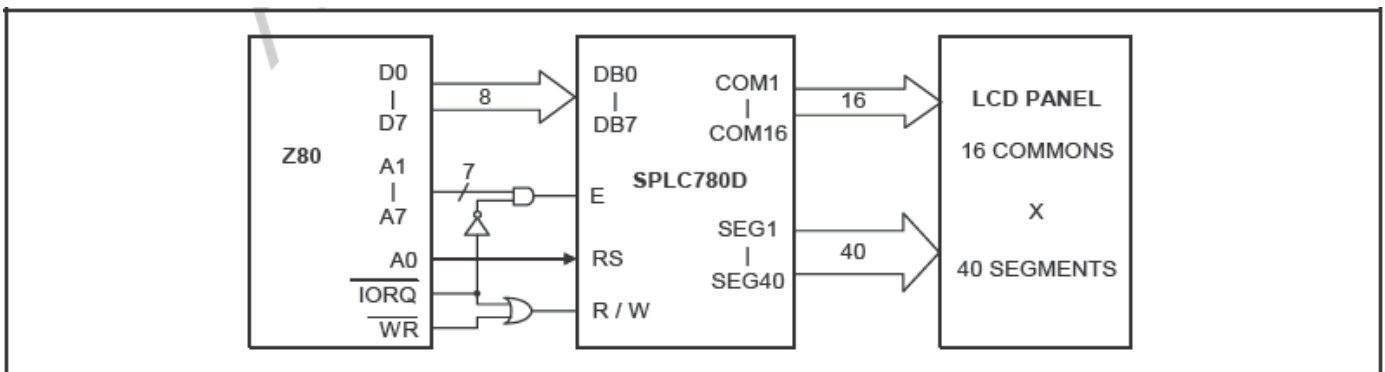

Figure 8.2 Interface to 8-bit MPU (Z80)

## 9. Electro-Optical Characteristics

Electro-Optical Characteristics(VDD=5.0V, Ta = 25 °C)

Item	Symbol	Condition	Min	Type	Max	Unit	Remarks	Note
Contrast ratio	Cr	---	2	3	---	---	---	1
Viewing angle	$\theta$	$Cr \geq 2$	35	---	---	deg	$\emptyset = 90^\circ$	2



range	35	---	---	deg	$\varnothing = 270^\circ$	2
	50	---	---	deg	$\varnothing = 0^\circ$	2
	33	---	---	deg	$\varnothing = 180^\circ$	2

**Figure 9.1 Definition of contrast ratio 'Cr'. & viewing angle range 'q'.**

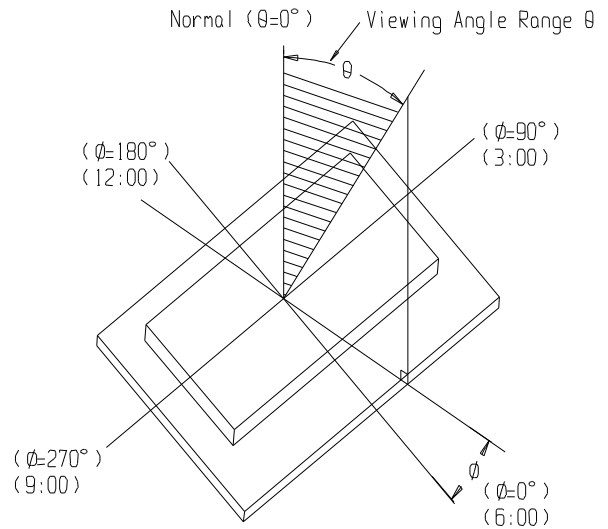
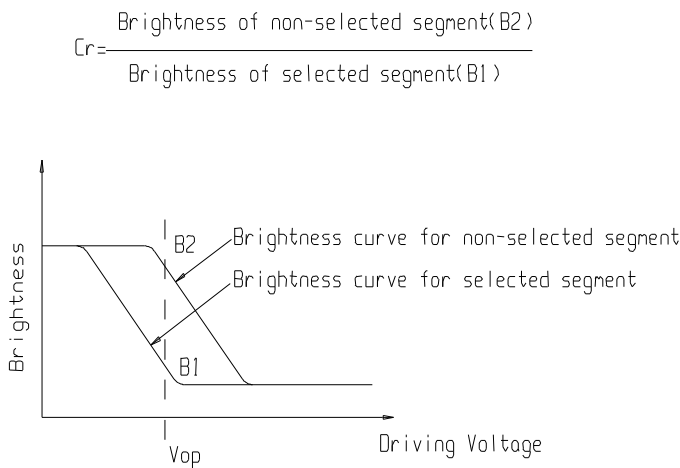

**Note1: Definition of contrast ratio Cr .**

**Note2: Definition of viewing angle range 'q'.**

## 10. Instruction Table

Instruction	Instruction Code										Description Instruction Code	Execution time (fsoc=270kHz)	
	RS	RW	DB7	DB6	DB5	DB4	DB3	DB2	DB1	DB0			
Clear Display	0	0	0	0	0	0	0	0	0	1	Write "20H" to DDRAM. and set DDRAM address to "00H" from AC.	1.53ms	
Return Home	0	0	0	0	0	0	0	0	0	1	X	Set DDRAM address to "00H" from AC and return cursor to its original position if shifted. The contents of DDRAM are not changed.	1.53ms
Entry Mode Set	0	0	0	0	0	0	0	0	1	I/D	SH	Assign cursor moving direction and make shift of entire display enable.	39ms
Display ON/OFF Control	0	0	0	0	0	0	0	1	D	C	B	Set display(D), cursor(C), and blinking of cursor(B) on/off control bit.	39ms
Cursor or Display Shift	0	0	0	0	0	0	1	S/C	R/L	X	X	Set cursor moving and display shift control bit, and the direction, without changing DDRAM data.	39ms
Function Set	0	0	0	0	0	1	DL	N	F	X	X	Set interface data length (DL : 4-bit/8-bit), numbers of display line (N : 1-line/2-line), display font type(F : 5 X 8 dots/ 5 X 11 dots)	39ms
Set CGRAM Address	0	0	0	1	AC5	AC4	AC3	AC2	AC1	AC0		Set CGRAM address in address counter.	39ms



Set DDRAM Address	0	0	1	AC6	AC5	AC4	AC3	AC2	AC1	AC0	Set DDRAM address in address counter.	39ms
Read Busy Flag and Address	0	1	BF	AC6	AC5	AC4	AC3	AC2	AC1	AC0	Whether during internal operation or not can be known by reading BF. The contents of address counter can also be read.	0ms
Write Data to RAM	1	0	D7	D6	D5	D4	D3	D2	D1	D0	Write data into internal RAM (DDRAM/CGRAM).	43ms
Read Data from RAM	1	1	D7	D6	D5	D4	D3	D2	D1	D0	Read data from internal RAM (DDRAM/CGRAM).	43ms

\*See the "SPLC780D" data sheet of SAMSUNG to get more detail.

## 11. Instruction Description

### Outline

To overcome the speed difference between internal clock of SPLC780D and MPU clock, SPLC780D performs internal operation by storing control information to IR or DR. The internal operation is determined according to the signal from MPU, composed of read/write and data bus. (refer to Table 5 ) Instruction can be divided largely four kinds,

- (1) SPLC780D function set instructions ( set display methods, set data length, etc.)
- (2) Address set instructions to internal RAM
- (3) Data transfer instructions with internal RAM
- (4) Others.

The address of internal RAM is automatically increased or decreased by 1.

**NOTE:** During internal operation, Busy Flag (DB7) is read High. Busy Flag check must precede the next instruction. When an MPU program with checking the Busy Flag (DB7) is made, it must be necessary 1/2 fosc for executing the next instruction by the falling edge of the 'E' signal after the Busy Flag (DB7) goes to "LOW".

### Contents

#### 1) Clear Display

RS	R/W	DB7	DB6	DB5	DB4	DB3	DB2	DB1	DB0
0	0	0	0	0	0	0	0	0	1

Clear all the display data by writing "20H" (space code) to all DDRAM address, and set DDRAM address to "00H" into AC (address counter). Return cursor to the original status, namely, bring the cursor to the left edge on first line of the display. Make entry mode increment (I/D = "1").

#### 2) Return Home

RS	R/W	DB7	DB6	DB5	DB4	DB3	DB2	DB1	DB0
0	0	0	0	0	0	0	0	1	-

Return Home is cursor return home instruction. Set DDRAM address to "00H" into the address counter. Return cursor to its original site and return display to its original status, if shifted. Contents of DDRAM does not change.

#### 3) Entry Mode Set

RS	R/W	DB7	DB6	DB5	DB4	DB3	DB2	DB1	DB0
0	0	0	0	0	0	0	1	I/D	SH

Set the moving direction of cursor and display.

**I/D : Increment / decrement of DDRAM address (cursor or blink)**

When I/D = "High", cursor/blink moves to right and DDRAM address is increased by 1.

When I/D = "Low", cursor/blink moves to left and DDRAM address is decreased by 1.

\* CGRAM operates the same as DDRAM, when read from or write to CGRAM.

**SH: Shift of entire display**

**SHEN ZHEN ET TECHNOLOGY CO., LTD.**

Tel: 86-755- 88834445

E-mail: east@eastet .com

Fax: 86-755-88834446

Http://www.eastet.com



When DDRAM read (CGRAM read/write) operation or SH = "Low", shift of entire display is not performed. If SH = "High" and DDRAM write operation, shift of entire display is performed according to I/D value (I/D = "1" : shift left, I/D = "0" : shift right).

#### 4) Display ON / OFF Control

RS	R/W	DB7	DB6	DB5	DB4	DB3	DB2	DB1	DB0
0	0	0	0	0	0	1	D	C	B

Control display/cursor/blink ON/OFF 1 bit register.

##### D : Display ON/OFF Control Bit

When D = "High", entire display is turned on.

When D = "Low", display is turned off, but display data is remained in DDRAM.

##### C : Cursor ON/OFF Control Bit

When C = "High", cursor is turned on.

When C = "Low", cursor is disappeared in current display, but I/D register remains its data.

##### B : Cursor Blink ON/OFF Control Bit

When B = "High", cursor blink is on, that performs alternate between all the high data and display character at the cursor position.

When B = "Low", blink is off.

#### 5) Cursor or Display Shift

RS	R/W	DB7	DB6	DB5	DB4	DB3	DB2	DB1	DB0
0	0	0	0	0	1	S/C	R/L	-	-

Shifting of right/left cursor position or display without writing or reading of display data. This instruction is used to correct or search display data (Refer to table 6). During 2-line mode display, cursor moves to the 2nd line after the 40th digit of the 1st line. Note that display shift is performed simultaneously in all the lines. When displayed data is shifted repeatedly, each line is shifted individually. When display shift is performed, the contents of the address counter are not changed.

**Table 6. Shift Patterns According to S/C and R/L Bits**

S/C	R/L	Operation
0	0	Shift cursor to the left, AC is decreased by 1
0	1	Shift cursor to the right, AC is increased by 1
1	0	Shift all the display to the left, cursor moves according to the display
1	1	Shift all the display to the right, cursor moves according to the display

#### 6) Function Set

RS	R/W	DB7	DB6	DB5	DB4	DB3	DB2	DB1	DB0
0	0	0	0	1	DL	N	F	-	-

##### DL : Interface Data Length Control Bit

When DL = "High", it means 8-bit bus mode with MPU.

When DL = "Low", it means 4-bit bus mode with MPU. So to speak, DL is a signal to select 8-bit or 4-bit bus mode.

When 4-bit bus mode, it needs to transfer 4-bit data by two times.

##### N : Display Line Number Control Bit

When N = "Low", it means 1-line display mode.

When N = "High", 2-line display mode is set.

##### F : Display Font Type Control Bit

When F = "Low", it means 5 × 8 dots format display mode

When F = "High", 5 × 11 dots format display mode.

#### 7) Set CGRAM Address

RS	R/W	DB7	DB6	DB5	DB4	DB3	DB2	DB1	DB0
0	0	0	1	AC5	AC4	AC3	AC2	AC1	AC0

Set CGRAM address to AC. This instruction makes CGRAM data available from MPU.

**8) Set DDRAM Address**

RS	R/W	DB7	DB6	DB5	DB4	DB3	DB2	DB1	DB0
0	0	1	AC6	AC5	AC4	AC3	AC2	AC1	AC0

Set DDRAM address to AC. This instruction makes DDRAM data available from MPU. When 1-line display mode(N = 0), DDRAM address is from "00H" to "4FH". In 2-line display mode (N = 1), DDRAM address in the 1st line is from "00H" to "27H", and DDRAM address in the 2nd line is from "40H" to "67H".

**9) Read Busy Flag & Address**

RS	R/W	DB7	DB6	DB5	DB4	DB3	DB2	DB1	DB0
0	1	BF	AC6	AC5	AC4	AC3	AC2	AC1	AC0

This instruction shows whether SPLC780D is in internal operation or not. If the resultant BF is High, it means the internal operation is in progress and you have to wait until BF to be Low, and then the next instruction can be performed. In this instruction you can read also the value of address counter.

**10) Write Data to RAM**

RS	R/W	DB7	DB6	DB5	DB4	DB3	DB2	DB1	DB0
1	0	D7	D6	D5	D4	D3	D2	D1	D0

Write binary 8-bit data to DDRAM/CGRAM. The selection of RAM from DDRAM, CGRAM, is set by the previous address set instruction (DDRAM address set, CGRAM address set). RAM set instruction can also determine the AC direction to RAM. After write operation, the address is automatically increased/decreased by 1, according to the entry mode.

**11) Read Data from RAM**

RS	R/W	DB7	DB6	DB5	DB4	DB3	DB2	DB1	DB0
1	1	D7	D6	D5	D4	D3	D2	D1	D0

Read binary 8-bit data from DDRAM/CGRAM. The selection of RAM is set by the previous address set instruction. If address set instruction of RAM is not performed before this instruction, the data that read first is invalid, because the direction of AC is not determined. If you read RAM data several times without RAM address set instruction before read operation, you can get correct RAM data from the second, but the first data would be incorrect, because there is no time margin to transfer RAM data. In case of DDRAM read operation, cursor shift instruction plays the same role as DDRAM address set instruction : it also transfer RAM data to output data register. After read operation address counter is automatically increased/decreased by 1 according to the entry mode. After CGRAM read operation, display shift may not be executed correctly.

**NOTE:** In case of RAM write operation, after this AC is increased/decreased by 1 like read operation. In this time, AC indicates the next address position, but you can read only the previous data by read instruction.

**12. Software Design Guide**

**SHEN ZHEN ET TECHNOLOGY CO., LTD.**

Tel: 86-755- 88834445  
E-mail: east@eastet .com

Fax: 86-755-88834446  
Http://www.eastet.com



## Initial code for reference

```
// Using MPU 8Bits interface
//===================================================== LCM initial =====//
void LCM_Initial(void)
{
    LCM_Data = 0;
    Write_Command(0x30,0);
    // Function Set : 8bit , one Lines, 5x8 Font Style, No Cursors, No Blink ,don't check busy flag
    Delays(5);
    Write_Command(0x30,0);
    Delays(5);
    Write_Command(0x30,0); //write three times to assure input effected
    Delays(5);
    Write_Command(0x30,1); //Function Set, check busy flag
    Write_Command(0x08,1); //Display off;check busy flag
    Write_Command(0x01,1); // Clear screen, curse return home ; check busy flag
    Write_Command(0x06,1); // Set Cursor,Display Shift ; check busy flag
    Write_Command(0x0C,1); // display on, cursor off, blink off ; check busy flag
}

//===================================================== write command=====//
void Write_Command (unsigned char com,BusyC)
{
    if (BusyC) Read_Status (); //if BusyC=0,don't check busy flag
    LCM_Data = com;
    LCM_RS = 0;
    LCM_RW = 0;
    LCM_E = 0;
    Delays(1);
    LCM_E = 1;
}

//===================================================== write data=====//
void Write_Data (unsigned char dat) //write data to lcm
{
    Read_Status(); //check busy flag
    LCM_Data = dat;
    LCM_RS = 0;
    LCM_RW = 1;
    LCM_E = 0;
    Delays(1);
    LCM_E = 1;
}

//=====================================================check busy flag=====//
unsigned char Read_Status (void)
{
    LCM_Data = 0xFF;
    LCM_RS = 0;
    LCM_RW = 1;
    LCM_E = 0;
    LCM_E = 0;
    LCM_E = 1;
    while (LCM_Data & 0x80);
    return(LCM_Data);
}
```



```
//=====write data to appointment address=====//  
void Putcharxy(unsigned char x, unsigned char y,unsigned char disp_data)  
{  
    y=y&(16 -1); // 16 character per line  
    x=x&(1-1); // 1 line display  
    if(y) x+=0x40;  
    x+=0x80;  
    Write_Command(x,1);  
    Write_Data (disp_data);  
}
```

### 13 . Character Pattern Table



Higher 4 bits Lower 4 bit	0000	0010	0011	0100	0101	0110	0111	1010	1011	1100	1101	1110	1111
xxxx0000	CG RAM (1)		0	1	2	3	4	5	6	7	8	9	A
xxxx0001	(2)	!	1	A	Q	a	q	.	°	°	°	°	°
xxxx0010	(3)	"	2	B	R	b	r	°	°	°	°	°	°
xxxx0011	(4)	#	3	C	S	c	s	°	°	°	°	°	°
xxxx0100	(5)	\$	4	D	T	d	t	°	°	°	°	°	°
xxxx0101	(6)	%	5	E	U	e	u	°	°	°	°	°	°
xxxx0110	(7)	&	6	F	V	f	v	°	°	°	°	°	°
xxxx0111	(8)	'	7	G	W	g	w	°	°	°	°	°	°
xxxx1000	(1)	(	8	H	X	h	x	°	°	°	°	°	°
xxxx1001	(2)	)	9	I	Y	i	y	°	°	°	°	°	°
xxxx1010	(3)	*	:	J	Z	j	z	°	°	°	°	°	°
xxxx1011	(4)	+	;	K	[	k	]	°	°	°	°	°	°
xxxx1100	(5)	,	<	L	¥	l		°	°	°	°	°	°
xxxx1101	(6)	-	=	M	]	m	°	°	°	°	°	°	°
xxxx1110	(7)	.	>	N	^	n	°	°	°	°	°	°	°
xxxx1111	(8)	/	?	O	_	o	°	°	°	°	°	°	■

## 14 . Precautions For Using LCD Modules

### Handling Precautions

SHEN ZHEN ET TECHNOLOGY CO., LTD.

Tel: 86-755- 88834445

E-mail: east@eastet .com

Fax: 86-755-88834446

Http://www.eastet.com



- (1) The display panel is made of glass. Do not subject it to a mechanical shock by dropping it or impact.
- (2) If the display panel is damaged and the liquid crystal substance leaks out, be sure not to get any in your mouth. If the substance contacts your skin or clothes, wash it off using soap and water.
- (3) Do not apply excessive force to the display surface or the adjoining areas since this may cause the color tone to vary.
- (4) The polarizer covering the display surface of the LCD module is soft and easily scratched. Handle this polarizer carefully.
- (5) If the display surface becomes contaminated, breathe on the surface and gently wipe it with a soft dry cloth. If it is heavily contaminated, moisten cloth with one of the following solvents :
  - Isopropyl alcohol
  - Ethyl alcohol
- (6) Solvents other than those above-mentioned may damage the polarizer. Especially, do not use the following.
  - Water
  - Ketone
  - Aromatic solvents
- (7) Exercise care to minimize corrosion of the electrode. Corrosion of the electrodes is accelerated by water droplets, moisture condensation or a current flow in a high-humidity environment.
- (8) Install the LCD Module by using the mounting holes. When mounting the LCD module make sure it is free of twisting, warping and distortion. In particular, do not forcibly pull or bend the I/O cable or the backlight cable.
- (9) Do not attempt to disassemble or process the LCD module.
- (10) NC terminal should be open. Do not connect anything.
- (11) If the logic circuit power is off, do not apply the input signals.
- (12) To prevent destruction of the elements by static electricity, be careful to maintain an optimum work environment.
  - Be sure to ground the body when handling the LCD modules.
  - Tools required for assembling, such as soldering irons, must be properly grounded.
  - To reduce the amount of static electricity generated, do not conduct assembling and other work under dry conditions.
  - The LCD module is coated with a film to protect the display surface. Exercise care when peeling off this protective film since static electricity may be generated.

### Storage Precautions

When storing the LCD modules, avoid exposure to direct sunlight or to the light of fluorescent lamps. Keep the modules in bags (avoid high temperature / high humidity and low temperatures below 0°C). Whenever possible, the LCD modules should be stored in the same conditions in which they were shipped from our company.

### Others

Liquid crystals solidify under low temperature (below the storage temperature range) leading to defective orientation or the generation of air bubbles (black or white). Air bubbles may also be generated if the module is subject to a low temperature.

If the LCD modules have been operating for a long time showing the same display patterns, the display patterns may remain on the screen as ghost images and a slight contrast irregularity may also appear. A normal operating status can be regained by suspending use for some time. It should be noted that this phenomenon does not adversely affect performance reliability.

To minimize the performance degradation of the LCD modules resulting from destruction caused by static electricity etc., exercise care to avoid holding the following sections when handling the modules.

- Exposed area of the printed circuit board.
- Terminal electrode sections.

### Liquid Crystal Display Modules

LCD is composed of glass and polarizer. Pay attention to the following items when handling.





(1) Please keep the temperature within specified range for use and storage. Polarization degradation, bubble generation or polarizer peel-off may occur with high temperature and high humidity.

(2) Do not touch, push or rub the exposed polarizers with anything harder than an HB pencil lead (glass, tweezers, etc.).

(3) N-hexane is recommended for cleaning the adhesives used to attach front/rear polarizers and reflectors made of organic substances which will be damaged by chemicals such as acetone, toluene, ethanol and isopropylalcohol.

(4) When the display surface becomes dusty, wipe gently with absorbent cotton or other soft material like chamois soaked in petroleum benzine. Do not scrub hard to avoid damaging the display surface.

(5) Wipe off saliva or water drops immediately, contact with water over a long period of time may cause deformation or color fading.

(6) Avoid contacting oil and fats.

(7) Condensation on the surface and contact with terminals due to cold will damage, stain or dirty the polarizers. After products are tested at low temperature they must be warmed up in a container before coming in contact with room temperature air.

(8) Do not put or attach anything on the display area to avoid leaving marks on.

(9) Do not touch the display with bare hands. This will stain the display area and degrade insulation between terminals (some cosmetics are detrimental to the polarizers).

(10) As glass is fragile. It tends to become or chipped during handling especially on the edges. Please avoid dropping or jarring.

### Installing LCD Modules

The hole in the printed circuit board is used to fix LCM as shown in the picture below. Attend to the following items when installing the LCM.

(1) Cover the surface with a transparent protective plate to protect the polarizer and LC cell.

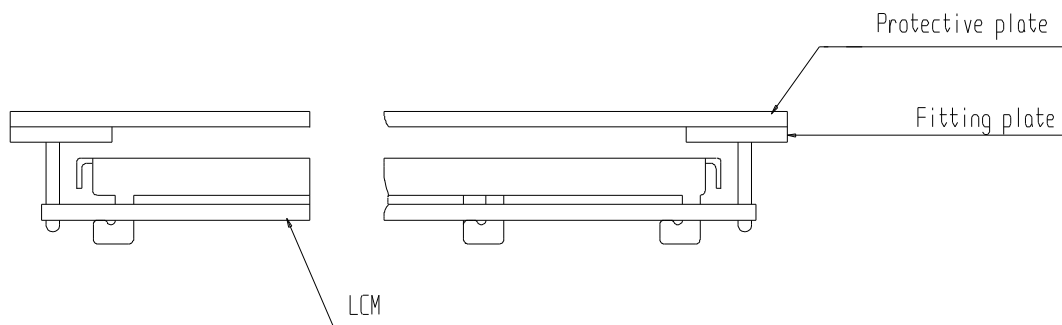

(2) When assembling the LCM into other equipment, the spacer to the bit between the LCM and the fitting plate should have enough height to avoid causing stress to the module surface, refer to the individual specifications for measurements. The measurement tolerance should be  $\pm 0.1$ mm.

### Precaution for Handling LCD Modules

Since LCM has been assembled and adjusted with a high degree of precision, avoid applying excessive shocks to the module or making any alterations or modifications to it.

(1) Do not alter, modify or change the shape of the tab on the metal frame.

(2) Do not make extra holes on the printed circuit board, modify its shape or change the positions of components to be attached.

(3) Do not damage or modify the pattern writing on the printed circuit board.

(4) Absolutely do not modify the zebra rubber strip (conductive rubber) or heat seal connector.

(5) Except for soldering the interface, do not make any alterations or modifications with a soldering iron.

(6) Do not drop, bend or twist LCM.

(7) In order to avoid the cracking of the FPC, you should pay attention to the area of FPC (R50mm) where the FPC was bent. the edge of coverlay; the area of surface of Ni-Au plating, the area of soldering land, the area of through hole.

### Electro-Static Discharge Control

Since this module uses a CMOS LSI, the same careful attention should be paid to electrostatic discharge as for an ordinary CMOS IC.

## SHEN ZHEN ET TECHNOLOGY CO., LTD.

Tel: 86-755- 88834445

E-mail: east@eastet .com

Fax: 86-755-88834446

Http://www.eastet.com



- (1) Make certain that you are grounded when handing LCM.
- (2) Before remove LCM from its packing case or incorporating it into a set, be sure the module and your body have the same electric potential.
- (3) When soldering the terminal of LCM, make certain the AC power source for the soldering iron does not leak.
- (4) When using an electric screwdriver to attach LCM, the screwdriver should be of ground potentiality to minimize as much as possible any transmission of electromagnetic waves produced sparks coming from the commutator of the motor.
- (5) As far as possible make the electric potential of your work clothes and that of the work bench the ground potential.
- (6) To reduce the generation of static electricity be careful that the air in the work is not too dried. A relative humidity of 50%-60% is recommended.

### Precaution for soldering to the LCM

- (1) Observe the following when soldering lead wire, connector cable and etc. to the LCM.
  - Soldering iron temperature :  $260^{\circ}\text{C} \pm 10^{\circ}\text{C}$ .
  - Soldering time : 3-4 sec.
  - Solder : eutectic solder.

If soldering flux is used, be sure to remove any remaining flux after finishing to soldering operation. (This does not apply in the case of a non-halogen type of flux.) It is recommended that you protect the LCD surface with a cover during soldering to prevent any damage due to flux spatters.

- (2) When soldering the electroluminescent panel and PC board, the panel and board should not be detached more than three times. This maximum number is determined by the temperature and time conditions mentioned above, though there may be some variance depending on the temperature of the soldering iron.
- (3) When remove the electoluminescent panel from the PC board, be sure the solder has completely melted, the soldered pad on the PC board could be damaged.
- (4) Soldering iron is not allowed to touch the surface of FPC's cover film directly.

### Precautions for Operation

- (1) Viewing angle varies with the change of liquid crystal driving voltage (VO). Adjust VO to show the best contrast.
- (2) Driving the LCD in the voltage above the limit shortens its life.
- (3) Response time is greatly delayed at temperature below the operating temperature range. However, this does not mean the LCD will be out of the order. It will recover when it returns to the specified temperature range.
- (4) If the display area is pushed hard during operation, the display will become abnormal. However, it will return to normal if it is turned off and then back on.
- (5) Condensation on terminals can cause an electrochemical reaction disrupting the terminal circuit. Therefore, it must be used under the relative condition of  $40^{\circ}\text{C}$  , 50% RH.
- (6) When turning the power on, input each signal after the positive/negative voltage becomes stable.

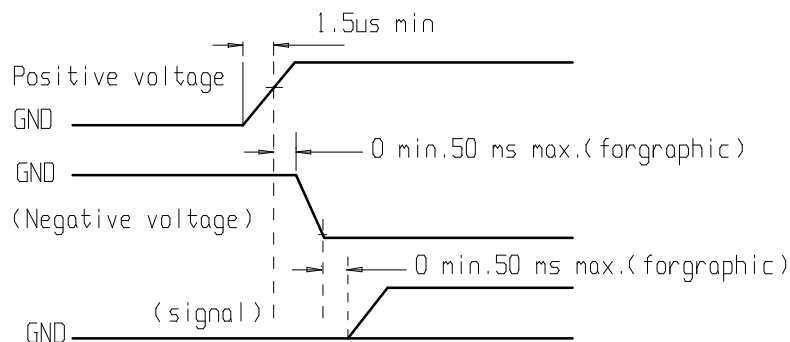

### Storage

**SHEN ZHEN ET TECHNOLOGY CO., LTD.**

Tel: 86-755- 88834445  
E-mail: east@eastet .com

Fax: 86-755-88834446  
Http://www.eastet.com



When storing LCDs as spares for some years, the following precaution are necessary.

- (1) Store them in a sealed polyethylene bag. If properly sealed, there is no need for dessicant.
- (2) Store them in a dark place. Do not expose to sunlight or fluorescent light, keep the temperature between 0°C and 35°C.
- (3) The polarizer surface should not come in contact with any other objects. (We advise you to store them in the container in which they were shipped.)
- (4) Environmental conditions :
  - Do not leave them for more than 160hrs. at 70°C.
  - Should not be left for more than 48hrs. at -20°C.

#### **Safety**

- (1) It is recommended to crush damaged or unnecessary LCDs into pieces and wash them off with solvents such as acetone and ethanol, which should later be burned.
- (2) If any liquid leaks out of a damaged glass cell and comes in contact with the hands, wash off thoroughly with soap and water.

#### **Limited Warranty**

Unless agreed between EAST and customer, EAST will replace or repair any of its LCD modules which are found to be functionally defective when inspected in accordance with EAST LCD acceptance standards (copies available upon request) for a period of one year from date of shipments. Cosmetic/visual defects must be returned to EAST within 90 days of shipment. Confirmation of such date shall be based on freight documents. The warranty liability of EAST limited to repair and/or replacement on the terms set forth above. EAST will not be responsible for any subsequent or consequential events.

#### **Return LCM under warranty**

No warranty can be granted if the precautions stated above have been disregarded. The typical examples of violations are :

- Broken LCD glass.
- PCB eyelet's damaged or modified.
- PCB conductors damaged.
- Circuit modified in any way, including addition of components.
- PCB tampered with by grinding, engraving or painting varnish.
- soldering to or modifying the bezel in any manner.

Module repairs will be invoiced to the customer upon mutual agreement. Modules must be returned with sufficient description of the failures or defects. Any connectors or cable installed by the customer must be removed completely without damaging the PCB's eyelet, conductors and terminals.